

PHOTOVOLTAIC 9724 THREE AND FIVE ZONE DRYING OVENS

The 9724 Infrared Drying Oven is designed to dry thin film coatings that have been applied to panelized parts. The system consists of three or five pairs of infrared sources that are independently temperature controlled to within 2°C providing highly uniform, repeatable drying to substrata. An additional drying element, convection heat is added via forced hot air system that simultaneously exposes the panelized substrata to convection heat and infrared radiation. A system exhaust is also supplied to provide the required air movement to remove any evaporated solvents.

The conveyor drive is a V-belt to minimize contact area between the panelized substrata and the drive belt. The conveyor speed is controlled to within 1% of full speed and is a direct drive DC motor type control.

ELECTRICAL SERVICE REQUIREMENTS

Circuit Breaker service is 3-phase configuration with a good Ground.

ITEM	208/240V 50/60HZ	380/400/415V 50HZ	480V 50/60HZ	POWER
9724 3 Heater Zones	150A	100A	70A	45kVA
9724 5 Heater Zones	250A	150A	100A	75kVA

Note: The 9724 requires a main exhaust blower that must have its own Electrical Service for safety purposes. The machine has an interlock that will not allow activation of the heat sources without proper exhaust.

EXHAUST SYSTEM REQUIREMENTS

MAIN EXHAUST

ITEM	VOLUME	BLOWER POWER	DUCTING
9724	1000 cu ft/min (28 cu m/min)	1/3HP	8" (203 mm) Inside Diameter

Note: Exhaust, Transition and ducting to be supplied by user.

WARNING

Make-up air to the installation area must be at least 1000 cu ft/min (28 cu m/min) for the **9724**. If the **9724 Drying Oven** is in line with a Spray Machine add another 2000 cu ft/min (57 cu m/min) for the 9524 Single sided sprayer to the make-up air total. Insufficient make-up air will result in fumes and over spray in the work area, causing the machine(s) to operate improperly.

SHIPPING DATA

ITEM	CRATE SIZE(S)	CRATED WEIGHT(S)	
		AIR FREIGHT	COMMON CARRIER
9724x3-20	188" x 63" x 63"	3,000 lbs.	3,200 lbs.
9724x3-60	232" x 63" x 63"	3,500 lbs.	3,700 lbs.
9724x5-20	262" x 63" x 63"	4,000 lbs.	4,200 lbs.
9724x5-60	188" x 63" x 63" and 63" x 63" x 63"	3,900 lbs. and 600 lbs.	4,100 lbs. and 800 lbs.

Note: Crating dimensions and weights are approximate and may vary within 10%.

Practical Application Guide

It is important at this point to reiterate that Argus International must be viewed as a full partner in aiding in the development of a complete understanding of the Thin Film Drying Process. Thin Film Drying is not an exact science principally because the number of nuances and influences that come into play as a result of the variations in topographic conditions, coating suppliers, cleanliness, maintenance, etc. The operator on the scene must have a firm understanding of the cause and effect of the solder mask application. This section of the operations manual is devoted to cultivating that understanding.

PHOTOVOLTAIC 9724 THREE AND FIVE ZONE DRYING OVENS

Parameters Overview

Quality thin film coating processing relies upon good manufacturing processes upstream including thin film coating application and surface preparation. It is essential to run test panels to establish the parameters below. Assuming the panels arrive at the Drying Oven with a quality surface, the following parameters will have the principle influence on the process:

Parameter	Normal Adjustment Range	Minimum	Maximum
Conveyor Speed	3 to 5 ft/min [.9 to 1.5 m/min]	2 ft/min [.6 m/min]	7 ft/min [2.1 m/min]
x3 Heater Zone 1	80 to 120° C	20° C	150° C
x3 Heater Zone 2	100 to 130° C	20° C	150° C
x3 Heater Zone 3	100 to 140° C	20° C	150° C
x5 Heater Zones 1 and 3	80 to 120° C	20° C	225° C
x5 Heater Zones 2 and 4	100 to 130° C	20° C	225° C
x5 Heater Zone 5	100 to 140° C	20° C	225° C
Thin Film Dry Thickness	.7 to 1.5 mils	.3 mil	2.5 mils

Conveyor Speed - is controlled to within 1% of full speed at all times.

Conveyor speed is a primary variable in the control of the solder mask drying ability.

x3 Heater Zone 1 - This zone controls the rate at which the solar panel reaches elevated temperature. Different coating materials can tolerate different heating rates. The range in the table above represents a place to start. Higher or lower temperatures may be beneficial for the particular material in use. Generally, it is desirable to start the solvent removal process as soon as possible, but the coating must be checked for **Micro bubbles** after drying. If they are present, simply lower the temperature set point in 5-degree increments until they are gone from the test panel.

x3 Heater Zone 2 - This zone removes the largest quantity of solvents from the coating. It uses a combination of air impingement as well as IR. Typically, this zone has the highest set point. This zone is adjusted for large changes in the level of drying.

x3 Heater Zone 3 - This zone controls the panel peak temperature. It finishes the drying process by removing residual solvents. If the panels are **slightly tacky**, raise the set point in 5-degree increments until the drying is complete. Let the panels completely cool before determining the level of drying. If an **over drying** condition occurs, simply reduce the set point in this zone until the test panel develops clean.

x5 Heater Zones 1 and 3 - These zones control the rate at which the circuit panel reaches elevated temperature. Different coating materials can tolerate different heating rates. The range in the table above represents a place to start. Higher or lower temperatures may be beneficial for the particular material in use. Generally, it is desirable to start the solvent removal process as soon as possible, but the coating must be checked for **Micro bubbles** after drying. If they are present, simply lower the temperature set point in 5-degree increments until they are gone from the test panel.

x5 Heater Zones 2 and 4 - These zones remove the largest quantity of solvents from the coating. It uses a combination of air impingement as well as IR. Typically, these zones have the highest set point. These zones are adjusted for large changes in the level of drying.

x5 Heater Zone 5 - This zone controls the panel peak temperature. It finishes the drying process by removing residual solvents. If the panels are **slightly tacky**, raise the set point in 5-degree increments until the drying is complete. Let the panels completely cool before determining the level of drying. If an **over drying** condition occurs, simply reduce the set point in this zone until the test panel develops clean.

Thin Film Dry Thickness capability is a function of the solder mask selected for processing. Typical coatings require approximately 1 mil nominal coating on laminate surfaces.

PHOTOVOLTAIC 9724 THREE AND FIVE ZONE DRYING OVENS

General Rules

The following general rules are based upon experiences earned during product development and live panel processing via Argus International's Process Engineering Group and Argus International Fabrication Processing Group.

1. During First Article Processing it is sometimes a good idea to process a first panel directly from Drying Oven through the developer without exposure. This will demonstrate whether the panel has been properly dried.
 - Over-drying will result in residues on the panel, which are dried and hard.
 - Under-drying will result in residues, which are gummy on the surface, because the residues contain non-aqueous solvents.
2. Typically, a thermal profile will be developed for a given coating. Then if a panel has a larger thermal load (relates to the mass of the panel) the speed may be adjusted faster or slower depending on the panel and the drying properties of the coating used.

**Panels must be allowed to cool to room temperature prior to exposure.
It is sometimes a good idea to extend the wait time by 10 minutes
to ensure that core of the panels is at room temperature.**

PHOTOVOLTAIC 9724 THREE AND FIVE ZONE DRYING OVENS

9724X3 RIGHT-HAND CONTROLS FACILITIES FLOOR PLAN

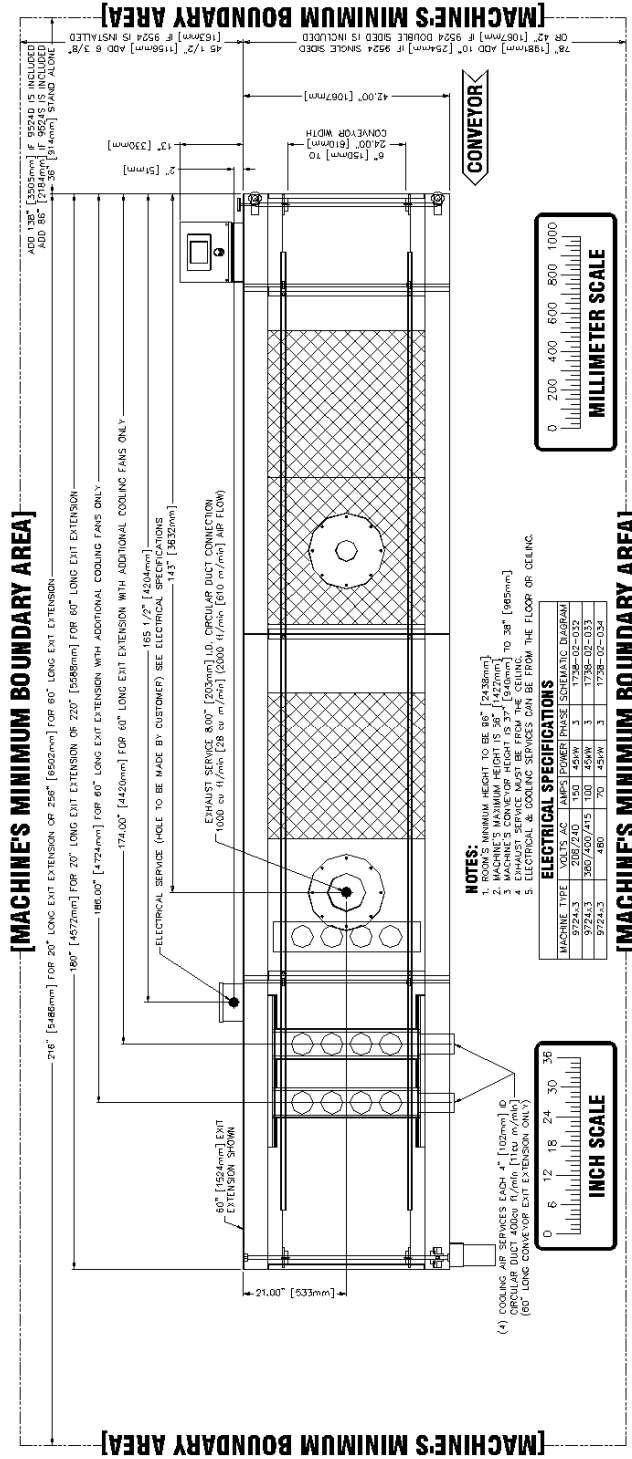

PHOTOVOLTAIC 9724 THREE AND FIVE ZONE DRYING OVENS

9724X3 LEFT-HAND CONTROLS FACILITIES FLOOR PLAN

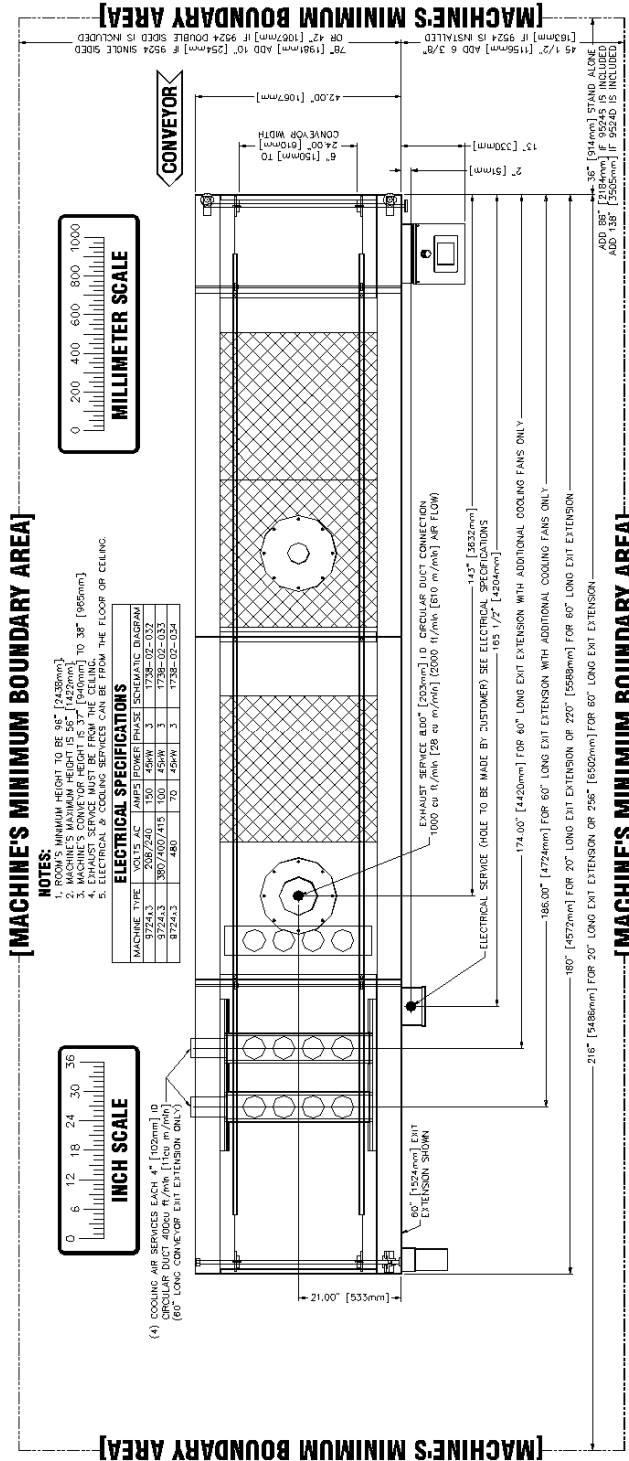

PHOTOVOLTAIC 9724 THREE AND FIVE ZONE DRYING OVENS

CONTROL AND OPERATING SCHEME 9724X3 ZONE DRYING OVEN

The 9724x3 is equipped with several key components, and the following figures identify the major elements of the machine. The operator should be completely familiar with these elements prior to attempting to operate the equipment. Argus International will provide on site training for process, operation and maintenance upon request.

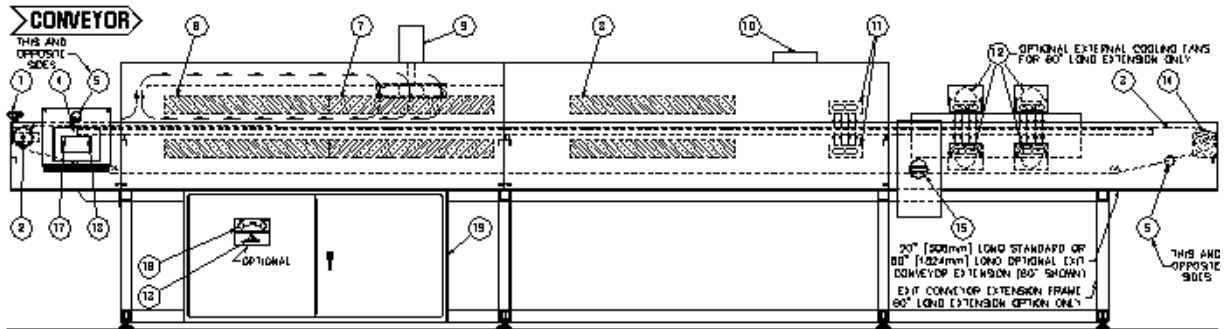

Figure: Major Components of the 9724x3 Zone Drying Oven with right-hand controls

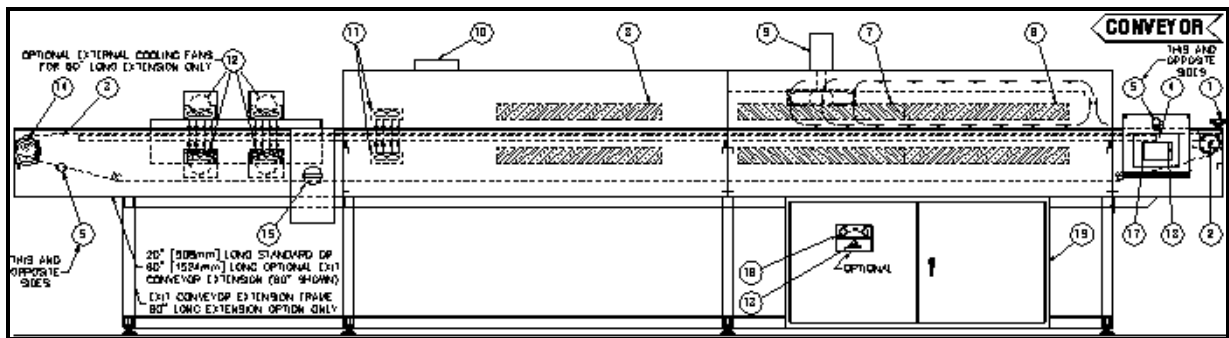

Figure: Major Components of the 9724x3 Zone Drying Oven with left-hand controls

- 1. Adjustable Entrance Conveyor Height** - An adjustment allowing for different board widths to provide a smooth transfer from the 9524S Spray System.
- 2. Conveyor Encoder** - This sensor detects and monitors conveyor movement and will send a signal to the controller to sound an alarm and turn off the heaters if the conveyor stops during operation.
- 3. V-Belt Conveyor System** - The materials coming into the 9724 are still wet with a thin film coating. It is necessary to provide a means to convey the part without touching the surface. The V-belt conveyor design allows conveyance without touching the panel surface.
- 4. Touch Screen Control** - This is the user's interface for communicating the machine's controller, therefore, allowing Start up, conveyor speed adjustment, heater settings, and programmed recipes.
- 5. Emergency-Stop Switches** - These switches cut power to the conveyor, heaters, convection blower, and heater cabinet cooling fans. These switches do not cut main power on the machine (see Circuit Breaker).
- 6. Heater Zone 1** - Heating panels that emit energy between 5 to 8 micron wavelength and provide the ideal preheating stage for drying without skinning over the liquid coating.
- 7. Heater/Convection Zone 2** - Includes the same 5 to 8 micron heating source that Zone 1 employs with the added feature of having high velocity air movement to break down the vapor barrier that forms on the surface of the panel during drying.
- 8. Heater Zone 3** - The final heating zone that provides some additional dwell time allowing completion of the drying process.
- 9. Convection Blower Motor** - High velocity air for Heater Zone 2 is supplied via convection fan. All ductwork is internal.
- 10. Exhaust Outlet** - The exhaust outlet for the 9724 disposes the evaporated solvents. An external blower rated at 1000 cu ft/min (28 cu m/min) and proper size duct must be connected to this outlet.
- 11. Internal Cooling Zone** - A short cooling zone is provided to reduce the exit panel temperature. The exit temperature may or may not allow direct handling by operators.

PHOTOVOLTAIC 9724 THREE AND FIVE ZONE DRYING OVENS

12. **Optional External Cooling Zone** - An extended cooling zone outside the heater cabinetry can be provided to further reduce the panel temperature. Air ducts can be attached to each of the 4" [102mm] outside diameter openings integrated to the four fan banks.
13. **Optional External Cooling Zone Control** – The operator can select a MINIMUM or MAXIMUM cooling output. The MINIMUM selection sets the first upper and lower fan banks off and the second upper and lower fan banks on. The MAXIMUM selection sets all four-fan banks on.
14. **Conveyor Drive Motor** - The conveyor system is equipped with a clutch. When the **SYSTEM OFF** indicator is lit, the operator can move the conveyor manually using the hand-wheel located at the entrance end of the machine.
15. **Circuit Breaker** - This is where the electrician connects the main power to the machine, and where main power of the machine can be switched on or off.
16. **Power Indicators** - These Indicator lights alert the operator or maintenance personal that power is connected to the machine.
17. **Exhaust Indicator** - This indicator is built into the touch screen, **EXHAUST ON**, alerts the operator or maintenance personal that the exhaust is activated.
18. **Start System Control and Indicator** - This control is built into the touch screen and starts the conveyor, heater cabinet fans, and prepares system for activation. The touch screen indicator, **SYSTEM ON**, alerts the operator or maintenance personal that the system is activated.
19. **Electrical Component Enclosure** - This cabinet contains the electrical wiring, any control boards and PLC controls.

PHOTOVOLTAIC 9724 THREE AND FIVE ZONE DRYING OVENS

Control and Operating Scheme 9724x5 Zone Drying Oven

The 9724x5 is equipped with many components, and the following figures identify the major elements of the machine. The operator should be completely familiar with these elements prior to attempting to operate the equipment. Argus International will provide on site training for process, operation and maintenance upon request.

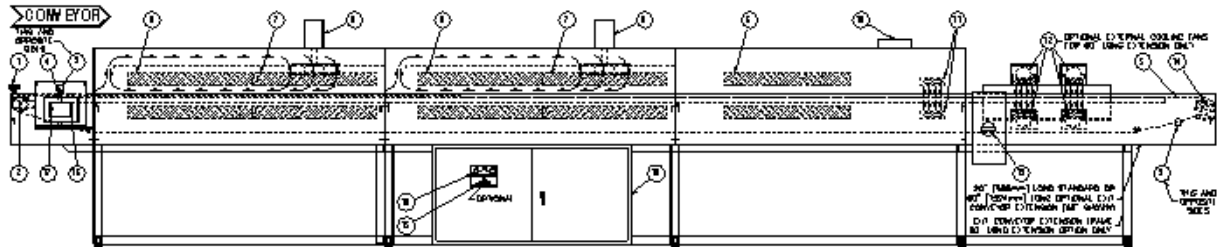

Figure: Major Components of the 9724x5 Zone Drying Oven with right-hand controls

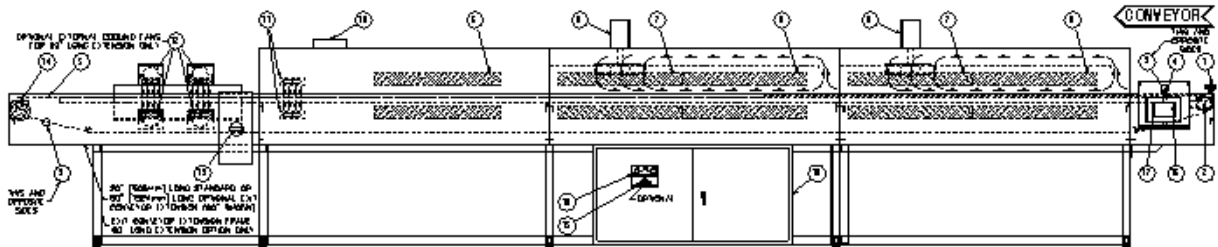

Figure: Major Components of the 9724x5 Zone Drying with left-hand controls

- 1. Adjustable Entrance Conveyor Height** - An adjustment allowing for different board widths to provide a smooth transfer from the 9524S Spray System.
- 2. Conveyor Encoder** - This sensor detects and monitors conveyor movement and will send a signal to the controller to sound an alarm and turn off the heaters if the conveyor stops during operation.
- 3. V-Belt Conveyor System** - The materials coming into the 9724 are still wet with a thin film coating. It is necessary to provide a means to convey the part without touching the surface. The V-belt conveyor design allows conveyance without touching the panel surface.
- 4. Touch Screen Control** - This is the user's interface for communicating the machine's controller, therefore, allowing Start up, conveyor speed adjustment, heater settings, and programmed recipes.
- 5. Emergency-Stop Switches** - These switches cut power to the conveyor, heaters, convection blower, and heater cabinet cooling fans. These switches do not cut main power on the machine (see Circuit Breaker).
- 6. Heater Zones 1 and 3** - Heating panels that emit energy between 5 to 8 micron wavelength and provide the ideal preheating stage for drying without skinning over the liquid coating.
- 7. Heater/Convection Zones 2 and 4** - Includes the same 5 to 8 micron heating source that Zones 1 & 3 employ with the added feature of having high velocity air movement to break down the vapor barrier that forms on the surface of the panel during drying.
- 8. Heater Zone 5** - The final heating zone that provides some additional dwell time allowing completion of the drying process.
- 9. Convection Blower Motors** - High velocity air for Heater Zones 2 and 4 are supplied via convection fan. All ductwork is internal.
- 10. Exhaust Outlet** - The exhaust outlet for the 9724 disposes the evaporated solvents. An external blower rated at 1000 cu ft/min (28 cu m/min) and proper size duct must be connected to this outlet.
- 11. Internal Cooling Zone** - A short cooling zone is provided to reduce the exit panel temperature. The exit temperature may or may not allow direct handling by operators.
- 12. Optional External Cooling Zone** - An extended cooling zone outside the heater cabinetry can be provided to further reduce the panel temperature. Air ducts can be attached to each of the 4" [102mm] outside diameter openings integrated to the four fan banks.

PHOTOVOLTAIC 9724 THREE AND FIVE ZONE DRYING OVENS

- 13. Optional External Cooling Zone Control** – The operator can select a MINIMUM or MAXIMUM cooling output. The MINIMUM selection sets the first upper and lower fan banks off and the second upper and lower fan banks on. The MAXIMUM selection sets all four-fan banks on.
- 14. Conveyor Drive Motor** - The conveyor system is equipped with a clutch. When the **SYSTEM OFF** indicator is lit, the operator can move the conveyor manually using the hand-wheel located at the entrance end of the machine.
- 15. Circuit Breaker** - This is where the electrician connects the main power to the machine, and where main power of the machine can be powered on or off.
- 16. Power Indicators** - These Indicator lights alert the operator or maintenance personal that power is connected to the machine.
- 17. Exhaust Indicator** - This indicator is built into the touch screen, **EXHAUST ON**, alerts the operator or maintenance personal that the exhaust is activated.
- 18. Start System Control and Indicator** - This control is built into the touch screen and starts the conveyor, heater cabinet fans, and prepares system for activation. The touch screen indicator, **SYSTEM ON**, alerts the operator or maintenance personal that the system is activated.
- 19. Electrical Component Enclosure** - This cabinet contains the electrical wiring, any control boards and PLC controls.